

LOGGER R0110

Temperature logger with internal sensor

Instruction manual

Manual for use of temperature logger R0110

Logger is designed for measurement and record of temperature from built-in internal temperature sensor. Measured values are stored in selectable time interval to internal nonvolatile memory. All logger control and setting are performed from the PC and password is applicable. It is enabled to switch ON and OFF the logger by delivered magnet (this possibility can be in configuration disabled). It is also enabled to program automatic start in certain day and time (for one month forward).

Switched ON logger every 10 seconds (independently on logging interval) updates MIN/MAX memory, compares measured values with two adjustable limits and exceeding of limits is indicated by blinking of red LED (alarm function). Also memory alarm mode is selectable, when alarm is indicated permanently till alarm memory reset.

Logging mode can be adjusted as non-cyclic, when logging stops after filling the memory. In cyclic mode oldest stored values are overwritten by new. In addition logging mode can be selected when logging is active only if measured value is out of adjusted alarm limits.

Stored values can be transferred from logger memory to the PC by means of communication adapter. Communication adapter can be connected to the logger permanently – data logging is not interrupted even if data download appears.

Logger evaluates minimum battery voltage and its drop below allowed limit is indicated by a red LED. At the same time remaining battery capacity is available in % by means of the PC program. It is valid if logger is operated at temperature from -5 to +35°C. If logger is operated often outside of the above temperature range battery life can be reduced to 75%, i.e. if displayed remaining battery capacity drops below 25%, it is recommended to replace the battery.

Technical parameters:

Ambient temperature (RTD Pt1000/3850ppm sensor):

Measuring range: -40 to +80 °C

Resolution: 0.1 °C

Accuracy: ± 0.4 °C

Response time: $t_{63} < 6$ min, $t_{90} < 16$ min (temperature step 20 °C, air flow approximately 1 m/s)

Measuring interval, alarm evaluation and MIN/MAX memory update: 10 s

Logging interval to memory: 10 s to 24 h (20 steps)

Memory capacity:

for non cyclic mode 32 504 records

for cyclic mode 28 896 records

Specified values are maximum possible and can be reached only if record is not interrupted (since last memory erasing)

Communication with computer: via RS232 (serial port) by means of COM adapter or USB port by means of USB adapter; data transfer from logger via communication adapter is optical

Real time clock: adjustable from computer, integrated calendar including leap years

Error of internal RTC: < 200 ppm (i.e. 0.02 %, 17.28 s in 24 h)

Power: Lithium battery 3.6 V size AA

Battery life:

typical (data download to PC is carried out about once a week): 7 years

in continuous on-line mode with interval 1 minute: approximately 4.5 years

in continuous on-line mode with interval 10 seconds: approximately 1 year

Notice: The above battery lives are valid for logger operation in temperature from -5 to +35°C. If often operated outside of the above temperature range battery life can be reduced to 75%.

Protection: IP67

Operational conditions:

Operational temperature range: -40 to +80 °C

Operational humidity range: 0 to 100 %RH

Specification of outer characteristics accordingly to Czech National Standard 33-2000-3:
normal environment accordingly to appendix NM: AE1, AN1, AR1, BE1

Operational position: negligible

Logger installation: by self adhesive Dual Lock, applied to clean, flat surface

Limit condition: temperature -40 to +80 °C, humidity 0 to 100 %RH

Storing condition: temperature -40 to +85 °C, humidity 0 to 100 %RH

Dimensions: 93 x 64 x 27 mm

Weight including battery: approximately 100 g

Material of the case: ABS

Logger operation

Logger comes complete with installed battery and switched OFF. Before operation it is necessary by means of installed user PC software to set logging parameters and other features. Free user program is available to download at www.cometsystem.cz. For communication with the PC a communication adapter is necessary (not included in delivery). For connection via RS232 serial port it is necessary to use COM ADAPTER, for connection via USB port it is necessary to use USB ADAPTER. Connect adapter connector to proper computer port and plug the adapter to the guide slots on the side of logger.

Connecting logger to the computer by means of communication adapter

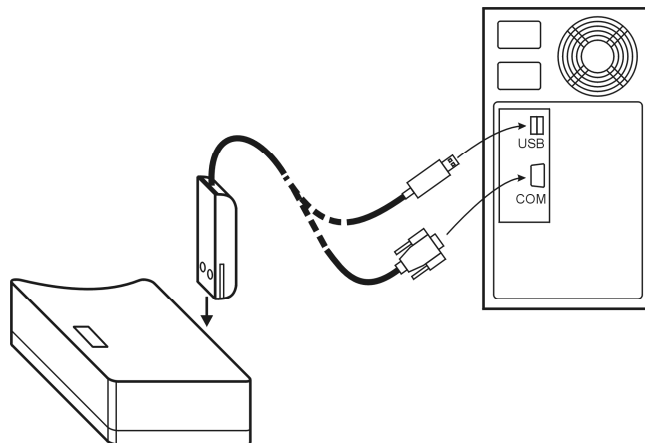

Notice: USB connector can be located also at the computer front side.

After connecting the logger to the computer reading of logger info is enabled by means of the PC software and also setting of the instrument accordingly to the user needs (menu *Configuration / Setting of instrument parameters*). Before logging start it is necessary:

- check or optionally set the logger real time clock
- select suitable logging interval
- select logging mode (cyclic or non cyclic)

- switch ON the logger (or switch OFF, if it is about to be switched ON by magnet or automatically with delayed start)
- enable or disable the option to switch ON the logger by magnet
- enable or disable the option to switch OFF the logger by magnet
- set date and time of logger automatic switching ON logger or disable this option
- select if record runs permanently or only if alarm is active
- If alarms are about to be applied, set both limits and enable alarm
- optionally enable permanent alarm (alarm with memory)
- reset memory of MIN/MAX values (if needed)
- check free space in data memory, optionally erase data memory of the logger
- enter password if protection against unauthorized manipulation with the logger is necessary

Logging interval between to subsequent measurements is specified by the user. Memorizing of the first value is synchronized with the internal real time clock, so the logging is performed at sharp multiples of minutes, hours and days. E.g. after starting the logging with the 15 minute interval the first value is not stored immediately, but after the internal clock gets the status of a quarter, a half or a whole hour. After starting the logging with the 6 hour interval the first value is stored at that whole hour to perform the storing also at 00.00, i.e. at the beginning of the day. First storing is performed at 6.00, 12.00, 18.00 or 00.00hour - at the hour from the above nearest to the logging start. After communication with computer or after start by magnet logger automatically waits for the nearest whole multiple of time and then first measurement is performed. This is also necessary to take into account when setting time of automatic logger switch ON.

Notice: If logger operates as permanently connected to the computer, using of magnet start/stop is disabled.

To enable the logger control by magnet is suitable only in cases, when possibility of unauthorized manipulation to the logger operation is eliminated.

Indication of logger state in usual operation

Switched OFF logger has both indication LEDs permanently OFF. It does not do any function except eventual communication with the PC and the consumption from battery is negligible. If any modification of configuration of switched OFF logger is done from the PC, yellow LED blinks shortly at the moment of sending data to logger and then immediately red LED to indicate, logger is still switched OFF.

After switching ON the logger yellow LED lights up for 2s and switched ON logger is indicated by repeated short blink of yellow LED marked LOG with 10s interval. If alarm is active, yellow and red LEDs blink simultaneously. To apply the alarm function, it is necessary to enable from the PC alarm evaluation and at the same time set its lower and upper limits. If measured temperature is inside of the limit range, alarm is not active. If measured value exceeds any of set limits, alarm is indicated. "Memory" alarm mode is selectable, when once indicated alarm is indicated permanently till it is reset from the PC. Alarm indication is also automatically reset with every new logger start.

If memory is filled in non-cyclic logging mode, record stops and logger switches OFF. This state is indicated by accelerated blinking of red LED with 3s interval.

state	LED	I	10 s	I
logger switched OFF	yellow red			
logger switched ON	yellow red	●		●
active alarm	yellow red	● ●		● ●
full memory	yellow red	●	●	●

Indication of the logger state beyond normal operation

If yellow LED lights up after start extra long (depending to memory occupation up to 12s), initialization of the logger proceeds. This can occur e.g. after totally discharged battery replacement. In that case correct time setting from the PC is necessary.

If red LED blinks immediately after yellow LED (do not mistake with active alarm indication!), end of calculated battery life is indicated – logger is fully functional, early battery replacement is recommended.

If **only** red LED blinks 2x with 3s interval, battery voltage is low and logger is not enabled to switch ON. If logger was originally switched ON, record is interrupted and logger is switched OFF. Communication with computer can work for limited period of time. Replace the battery as soon as possible!

state	LED	I	10 s	I
end of battery life	yellow red	● ●		● ●
low battery	yellow red	● ●	● ●	● ●

Procedure of switching ON / OFF the logger by magnet

Start / stop by magnet

The function must be enabled from the PC before. If only switching OFF by magnet is enabled, it is of course necessary to switch ON the logger from the computer.

Switching the logger ON by magnet

Plug magnet to guide slots from logger front side and wait approximately 1 s for yellow LED to light up. After lighting up it is necessary immediately (till it lights) to remove magnet from guide slots and logger switches ON and yellow LED blinks every 10s. If magnet is applied for more than 3s yellow LED goes out and logger remains switched OFF.

Switching the logger OFF by magnet

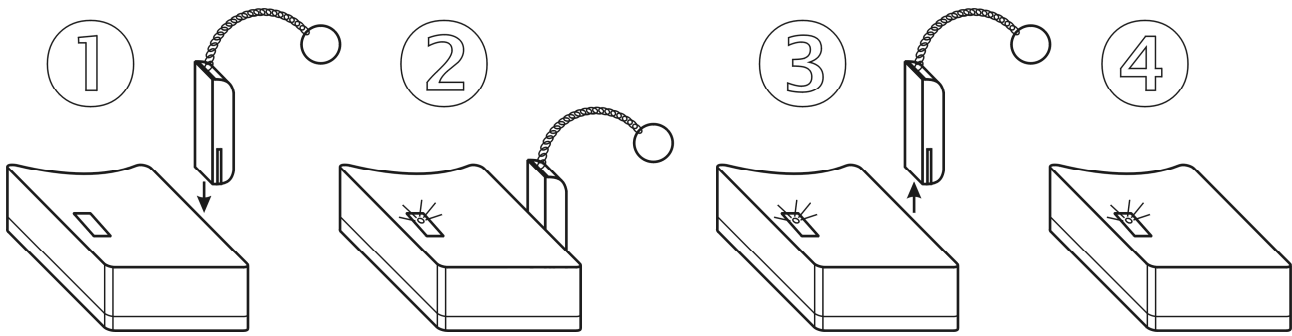

The procedure is identical with the above procedure for switching ON. If indication yellow LED does not light up to 1 second after plugging the magnet, it is necessary to unplug magnet and repeat the procedure.

Battery replacement

Low battery is indicated by red LED, which blinks itself (without yellow LED – see tables above). Replace the battery for new one. If logger is operated often in temperature below -5°C or over $+35^{\circ}\text{C}$ and PC program indicates remaining battery capacity below 25% it is also recommended to replace the battery. Applied is Lithium battery 3.6 V, size AA. Battery is located under logger lid.

Warning: near battery fragile glass reed contact is located – be careful not to damage it. Be careful in battery replacement!

Replacement procedure:

- switch off the logger by the PC program or by magnet (if low battery allows)
- unscrew four corner screws and remove the lid
- remove old battery by pulling the glued tape
- insert new battery **respecting the correct polarity** (see symbols + and – near battery holder). If you connect new battery up to 30 s, all logger settings remain unchanged. In the opposite case check by means of PC program all settings, especially the real time clock in logger. **Attention, inserted battery with incorrect polarity causes logger damage!**
- put the lid back again and screw four screws. Be careful to have the rubber sealing properly in the slot and tighten the screws properly to ensure the water resistance of the instrument.
- connect logger to the computer and **write to it the information on battery replacement** (menu Configuration/Battery replacement). This step is necessary to evaluate properly the remaining battery capacity.

Discharged battery or entire instrument after its life liquidate ecologically – in special deposit!

Instruments passed the following electromagnetic compatibility (EMC) tests:

radiation:	EN 55022	class B
immunity:	EN 61000-4-2	(levels 4/8 kV, class A)
	EN 61000-4-3	(intensity of electromagnetic field 3 V/m, class A)
	EN 61000-4-4	only types with external probes (levels 1/0,5 kV, class A)
	EN 61000-4-6	only types with external probes (intensity of electromagnetic field 3 V/m, class A)