

LP040

The GPRS modem for data loggers Sxxxx, Rxxxx

The instruction manual



Please read the instruction manual before the first device connection.

This version describes FW 1.0.1

Contents

1.	Description of working of the modem	4
2.	General safety rules.....	5
3.	The modem and its accessories.....	7
3.1.	Accessories needed to operation	7
•	The SIM card	7
•	The GSM antenna	7
•	The electric power supply	7
•	The COM adapter LP002.....	7
•	The data logger.....	8
•	The paid version of program for data loggers SWR001	8
•	The M2MTalk server service.....	8
3.2.	Additional accessories.....	8
•	The setting cable QMS2901.....	8
•	The self-adhesive Dual Lock MD036.....	9
•	The modem wall holder MP036.....	9
•	The modem DIN rail 35mm holder MP037.....	9
4.	Quick installation	10
4.1.	Check of accessories	10
4.2.	Software installation	10
4.3.	The modem assembling	10
4.3.1.	The SIM card	10
4.3.2.	The GSM antenna	11
4.3.3.	Connecting the power supply adapter.....	11
4.3.4.	The data logger and the modem interconnection	12
4.4.	Switching on the modem.....	12
4.5.	Setting up the modem	13
4.5.1.	Setting of GPRS connection parameters.....	13
4.5.2.	Setting of M2MTalk client parameters	13
4.6.	Login the modem on the M2MTalk server	13
4.7.	Setting of the other parameters	14
5.	Communication via SMS messages.....	15
5.1.	The query SMS messages	15
5.1.1.	The query about the current values	15
5.1.2.	The query about the current values and their alarm limits.....	16
5.1.3.	The query about the modem firmware version	16
5.1.4.	The query about the current modem state information.....	17
5.2.	The statement SMS messages	17
5.2.1.	Login on the M2MTalk server.....	17
5.2.2.	Logout from the M2MTalk server	17
5.2.3.	Restart of the modem	18
5.2.4.	Information about the GPRS connection settings	18
5.2.5.	Setting of the GPRS connection.....	19
5.2.6.	Information about the M2MTalk server connection settings.....	19
5.2.7.	Setting of the M2MTalk server connection	20
5.2.8.	Information about permitting of the alarm SMS messages.....	21
5.2.9.	Setting of permitting of the alarm SMS messages.....	21
5.3.	The alarm SMS messages	22
5.3.1.	The measured value exceeds the alarm limit	22

5.3.2.	The data logger states.....	23
6.	Settings of the program for data loggers to use it with the modem	24
6.1.	Settings of the communication with the modem and the modem parameters	24
6.2.	Setting of the data logger parameters.....	30
6.3.	Setting of the modem using the setting cable	30
7.	Technical specification	31
7.1.	Technical parameters	31
7.2.	The modem interface	31
7.3.	A directory information about dimensions with the GSM antenna MP009/1	32
7.4.	Dimensional drawing for a wall mounting of the modem with MP036	32
7.5.	Dimensional drawing for a DIN rail mounting of the modem with MP037.....	33
7.6.	Description of the indicator LEDs	33
7.7.	The list of the supported data logger types	34
8.	Technical support.....	34
9.	Liquidation.....	34

1. Description of working of the modem

The modem is intended for remote communication with a data logger Sxxxx, Rxxxx via cellular network (GSM). In light of a customer, this way of communication offers the same functions like a direct connection between the data logger and the computer by using COM/USB adapter.

The modem can be set and controlled with a program for data loggers and also with SMS messages (but with restrictions). It is possible to select phone numbers, from which SMS messages are accepted by the modem.

These are possibilities of usage the program for data loggers:

- downloading data from the connected data logger
- reading of current values from the connected data logger
- setting up the modem locally via RS232 link
- setting up the modem remotely via GPRS networking
- setting up the connected data logger remotely

These are possibilities of usage the SMS messages:

- sending of alarm SMS messages to preconfigured phone numbers (in case of beyond the set alarm limits for measured values or in case of error conditions)
- getting of current values from the connected data logger
- setting up the modem remotely (with restrictions)

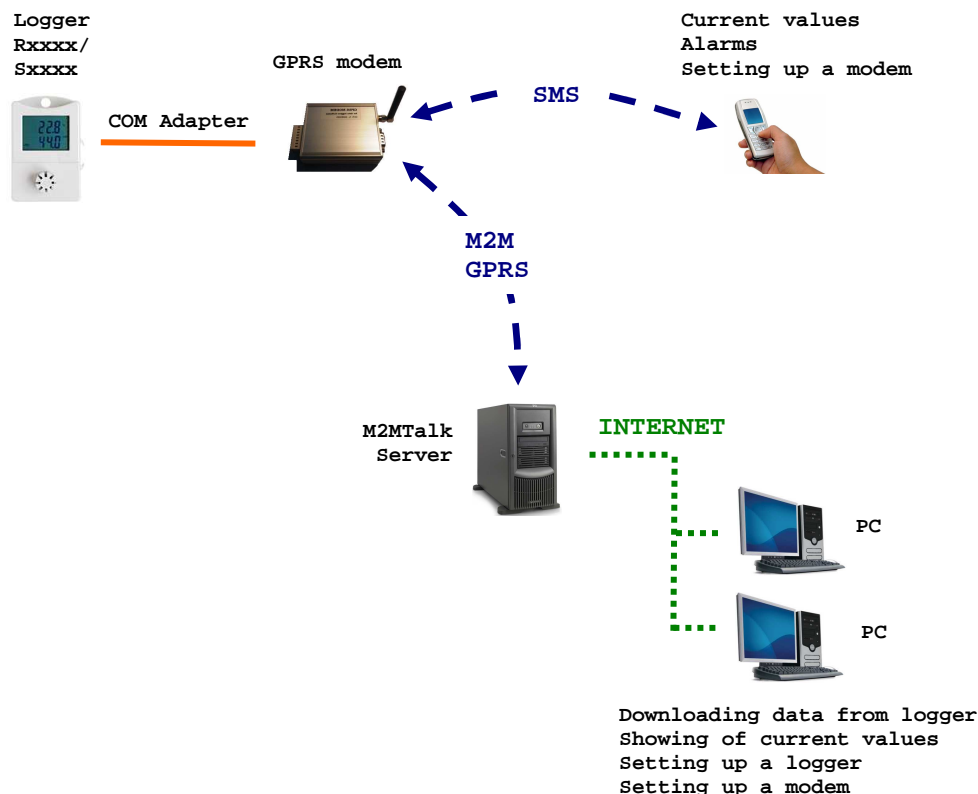

Working principle for the modem with the data logger (block diagram)

2. General safety rules

The following summary describes a basic safety features related to device installation and operation. Please read it properly before device installation. The following safety precautions must be observed during all phases of the operation, usage, installation or repair of the device. Operate the instrument in accordance with this manual to prevent damage of this device, damage of three-side devices or electric trauma.



Risk of electric shock

Do not use the instrument without the cover. Use only a safety adapter with the power voltage recommended by device manufacturer. Before connecting, check that the adapter has undamaged cables and cover. **Do not use the instrument, if it does not work correctly.** If the instrument seems not to work correctly, have it checked by a qualified service person.



Qualified service and installation

Service should be performed by a qualified person only. We recommend you use only original accessories to avoid possible damage. When connecting to any other device, read its user guide for detailed safety instructions. **Do not connect incompatible products. It is forbidden to connect other devices, while the device is under electric voltage.** If a damage of the device occurs due to gross violation of these rules, a free guarantee repair will not have to be executed.



Usage in hospitals

When in a hospital or other health care facility, observe the restrictions on the use of mobiles. Respect the directions and switch the cellular device off on places, where using mobile phones is forbidden. Medical equipment may be sensitive to RF energy.



Switch off in aircraft

Switch off the cellular device before boarding an aircraft. Make sure it cannot be switched on inadvertently. The operation of wireless appliances in an aircraft is forbidden to prevent interference with communications systems.



Avoid fire and explosion

Do not use the instrument in an explosive environment. Do not operate the cellular device in the presence of flammable gases or fumes. Switch off the cellular device when you are near petrol stations, fuel depots, chemical plants or where blasting operations are in progress. Operation of any electrical equipment in potentially explosive atmospheres can constitute a safety hazard.



Interference

Your cellular device receives and transmits radio frequency energy while switched on. Remember that interference can occur if it is used close to TV sets, radios, computers or inadequately shielded equipment. Always switch off the cellular device wherever forbidden, or when you suspect that it may cause interference or danger.



Service availability

Devices operate using radio signals and cellular networks. Because of this, connection (SMS, GPRS, etc.) cannot be guaranteed at all times under all conditions. Therefore, you should never rely solely upon any wireless device for essential communications (emergency systems, safety-related systems). Remember, for hi-reliability systems is redundancy necessary. For more information please see IEC 61508.

3. The modem and its accessories

To use the entire facility, not only the modem, but proper accessories are also required.

3.1. Accessories needed to operation

- **The SIM card**

The SIM card is necessary for correct modem operation. It makes possible to send SMS messages and to communicate with the data logger remotely via GPRS. In addition, GPRS tariff must be activated for data transferring via GPRS. Method and amount of payment for these services are determined by your mobile operator.

A PIN code entering must be deactivated on the SIM card. For more details see the chapter *The SIM card* on page 10.

- **The GSM antenna**

The GSM antenna is also necessary for correct modem operation, the facility doesn't work without it. It must be mounted into antenna SMA connector. It is possible to use the compact GSM antenna MP009/1 which is offered by the manufacturer. In case of need, an external GSM antenna can be used.

- **The electric power supply**

The modem must be powered from an external power supply (a power supply adapter, an accumulator battery). A power supply is connected to a supply terminal block. The supply terminal block is a modem component. It is possible to use the power supply adapter A1940 which is offered as optional equipment by the manufacturer.

- **The COM adapter LP002**

The adapter is intended for the data logger and the modem interconnection via RS232 serial link. This adapter provides a communication between the modem and the data logger. The length of the cable is cca. 160 centimeters.



- **The data logger**

The data logger is a target device. The modem is intended for communication with this device. Generally, the data logger types Sxxxx and Rxxxx are supported. A complete list of the supported devices can be found in the chapter *The list of the supported data logger types* on page 34.

- **The paid version of program for data loggers SWR001**

This program makes possible to change of modem settings, to communicate with the data logger, to read information about actual settings and data logger status, to change parameters for data recording and to read measured data. Minimal program version must be 2.1.7.0. The latest program versions are available on www.cometsystem.cz. A GPRS connection or a setting cable (for example if the GPRS connection is not activated) can be used for setting of the modem with this program.

- **The M2MTalk server service**

If you want use SMS messages only, you will not have to activate this service. For anything else (like remote communication with the data logger including data downloading), this service must be activated. By default, this service is already activated by manufacturer. In addition, if this service is used, *GPRS* must be activated on your SIM card. Method and amount of payment for this service are determined by valid trading conditions.

3.2. Additional accessories

- **The setting cable QMS2901**

The cable is intended for setting of the modem with the program for data loggers (from the computer) via RS232 serial link. It is needed for service purposes only, possibly for local settings of the modem during its activation, for example if the GPRS connection is not activated. Using of standard RS232 crossover cable as current computer equipment is alternative variation. New computers are not equipped with serial COM port generally. For solution of this problem, the converter MP006 (RS232/USB) is offered. It is plugged between computer USB port and the setting cable. After installing included driver, a virtual serial port in the computer is created for communication with the instrument.

- **The self-adhesive Dual Lock MD036**

The industrial hook-and-loop fastener for easy installation of the modem on a flat surface.



- **The modem wall holder MP036**

The modem wall holder includes 2 screws for mounting on the back side of the modem and set of 2 pieces of wall plugs + 2 pieces of screws for mounting on the wall.



- **The modem DIN rail 35mm holder MP037**

The modem DIN rail 35 mm holders include 4 screws for mounting on the back side of the modem.



4. Quick installation

4.1. Check of accessories

Make sure you have available all accessories needed to operation (the SIM card, the GSM antenna, the power supply adapter, the COM adapter, the data logger, the pay version of program for data loggers and access to the M2MTalk server service, if you want to use it).

4.2. Software installation

Install *the paid version of program for data loggers* (minimally the version 2.1.7.0) on the computer, from what you want to have access to the device. The latest program version is available on www.cometsystem.cz. Please follow instructions of the installer during installation process.

If you have activated a GPRS tariff, you will use the GPRS connection for setting of the modem. In this case, installation of any others drivers is not needed.

If you want to set up the modem by using the setting cable via RS232 interface (for example when you have not activated a GPRS tariff), you must also install *driver for GPRS modem configuration* which is available on above web address too.

4.3. The modem assembling

4.3.1. The SIM card

You must have activated a GPRS tariff if you want to communicate with the data logger remotely via GPRS. **A PIN code entering must be deactivated** on the SIM card.

Using the SIM card in any mobile phone is the simplest method how to make sure that a PIN code entering is deactivated. If a demand for entering a PIN code is displayed after switching the mobile phone on, you will have to deactivate a PIN code entering. This procedure is dependent on a type of the mobile phone and it should be described in a mobile phone's user manual.

The SIM card is put in a holder. The holder is a modem component. The holder is ejected by pressing the button beside the holder by using a fit instrument, for example a pencil. Insert the prepared SIM card into the holder. See that the SIM card stays in alignment with the holder correctly for all its size. After it, the holder with the inserted SIM card is pushed in the modem. The correct way to install the SIM card is shown in the picture.



The way to install the SIM card

4.3.2. The GSM antenna

The GSM antenna must be mounted to the antenna connector by lightly tightening a sleeve nut.

4.3.3. Connecting the power supply adapter

The power supply adapter is connected on a WAGO terminal block which is a modem component. Insert a flat-bladed screwdriver to rectangle terminal hole and push the screwdriver towards away from you – the contact is released. Connect a wire to the released terminal and close the terminal by removing the screwdriver. Connect positive pole of the terminal marked with + and negative pole of the terminal marked with –. The correct way to connect wires is shown in the pictures given below. In the case of using the power supply adapter A1940, connect the white wire to positive pole and the black wire to negative pole.

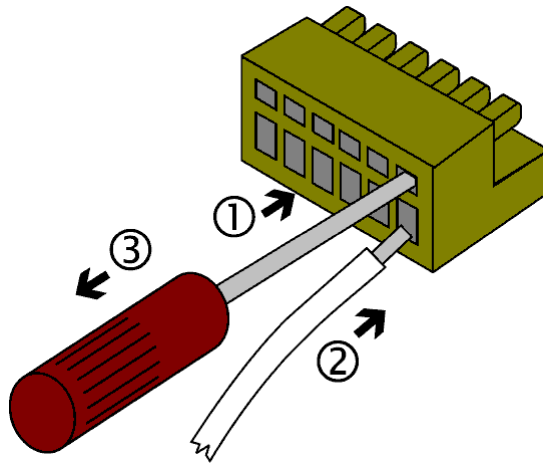

Way to connect wires

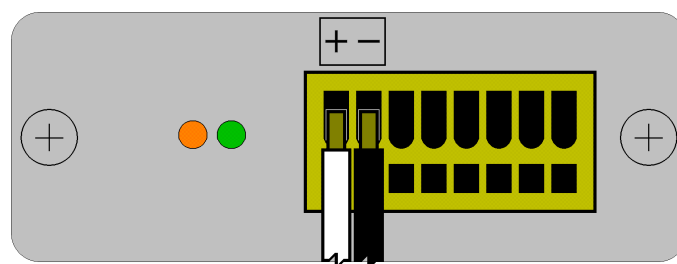

The supply terminal block

The entire terminal block is possible to remove from the modem by pulling it up from the connector.

4.3.4. The data logger and the modem interconnection

The data logger and the modem interconnection is provided with the *COM adapter*. Connect the adapter connector to the RS232 connector on the modem and plug the adapter to the guide slots on the side of the data logger. Heed to keep a minimum distance between the modem antenna and the data logger during installation to prevent the data logger interference. This distance may not be in any case less than 50 centimeters. Keeping the distance at least 1 meter is recommended. See the picture.

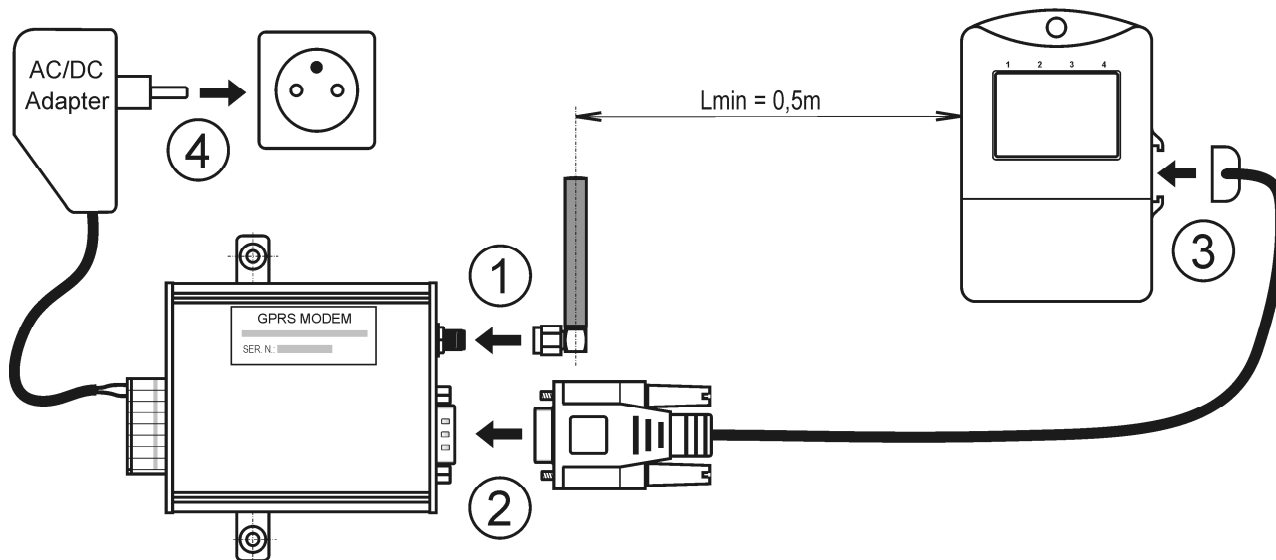

The data logger, the modem and other accessories interconnection

4.4. Switching on the modem

The properly assembled modem is switched on by connecting the power supply adapter to electrical power network. The green LED diode lights up. The modem will be prepared for communication after cca. 1 minute from its switching on. It is advisable to check the communication by sending SMS message **gsmstatus** to the modem phone number. A response delivery time is generally dependent on a momentary cellular network load and state. If the modem works correctly, it will send back SMS message with its state information. If you don't receive the response to this SMS message, please check your SIM card settings and your power supply adapter and aerial connection.

If communication with the modem via cellular network is impossible, you can try to find a problem with the program for data loggers. In this case, you must interconnect the modem and the computer via the setting cable, see the chapter *The setting cable QMS2901* on page 8.

4.5. Setting up the modem

If you don't intend to use remote communication with the data logger via GPRS, you can go to the chapter *Setting of the other parameters* on page 14.

4.5.1. Setting of GPRS connection parameters

If you didn't specify the GPRS connection parameters before ordering the modem, you must set it up now.

To do it, you can send a special SMS message to the modem phone number. The first word of the message must always be **gprs**. After this keyword, parameter values for an actual setting follows in specific order (see below):

gprs [apn] [user] [password] [dns]

If the trailing parameter values are not entered, they will be deleted. Don't enter the square brackets in the SMS message. Individual items of the message must be separated by spaces. For more detailed information about setting this parameter values via SMS command see the chapter *Setting of the GPRS connection* on page 19.

The example: You can set up the parameter *apn* to value *internet* without other parameters (*user*, *password* and *dns*) by sending the SMS message

gprs internet

For getting information about GPRS connection parameters please contact an appropriate mobile operator.

4.5.2. Setting of M2MTalk client parameters

These parameters are already preset at the factory, don't change it gratuitously! If you can verify a setting, compare it with data listed in the card which was delivered with the modem.

M2MTalk client parameters can be set via the SMS command (see the chapter *Setting of the M2MTalk server connection* on page 20) or via the setting cable (see the chapter *Setting of the modem using the setting cable* on page 30).

4.6. Login the modem on the M2MTalk server

If you intend to use remote communication with the modem or data logger via GPRS (for example to set up this device remotely), the modem always must be logged on the M2MTalk server before starting the communication. The modem can be set up to login on the server automatically after its switching on, but it isn't a standard factory setting.

To login the modem on the M2MTalk server, you can send a SMS message **login** to the modem phone number. The modem will send back an acknowledge SMS message. It is advisable to check the login status by sending SMS message **gsmstatus** to the modem phone number. If the modem works correctly, it will send back SMS message with information. The login status is also including in these information (M2MTalk online: yes).



Attention! Since the modem is logged on, a limited data transferring also proceeds in case the remote communication with the device isn't in progress (due to keeping the connection). Transferred data is charged as per your GPRS tariff by the mobile operator. Logout from the server is described in the chapter *Logout from the M2MTalk server* on page 17.

4.7. Setting of the other parameters

The information about exceeding of alarm limits and about correct operation of the data logger can be periodically taken from the data logger by the modem. These information are processed and then the modem sends alarm SMS messages to a customer according to these analyses.

The program for data loggers is used for setting of these parameters. If GPRS connection isn't activated, you will have to set up the modem by using the setting cable.

There are these parameters:

- data logger reading interval, see the chapter 6.1 on page 24
- sending / no sending of the warning SMS messages, see the chapter 6.1 on page 24
- phone numbers for the warning SMS messages recipients, see the chapter 6.1 on page 24
- phone numbers, from which the incoming SMS messages will be accepted by the modem, see the chapter 6.1 on page 24
- setting of the alarm limits for the data logger if this functionality is required, see the chapter 6.2 on page 30

5. Communication via SMS messages

It is possible to control and monitor the device operation remotely via the special SMS messages, which are being sent to the modem phone number. The user can select phone numbers, from which the SMS messages are accepted by the modem. The factory configuration doesn't restrict the phone numbers for any incoming SMS messages that means any SMS messages are accepted regardless of the sender phone number. Phone numbers restriction can be done with *the program for data loggers*, see the chapter *Settings of the program for data loggers to use it with the modem* on page 24.

Generally, SMS command messages aren't case sensitive and the space serves as a parameter separator.

If the accepted command isn't supported or it hasn't a correct syntax or parameters, the modem will send back an SMS message with a proper error description. This information will be returned only three times in maximum. The fourth and every next incorrect command from the one phone number is ignored until the incoming command will be correct again.

5.1. The query SMS messages

Using these messages, you can take the current measured values from the connected data logger, the modem firmware version and the current modem state information.

5.1.1. The query about the current values

To take the current measured values from the connected data logger, send the SMS message **values** to the modem. The modem will send back a SMS message with the following contents:

- *data logger identification* – the user's description of the data logger is displayed. If this description isn't set, the serial number of the data logger will be displayed. If the total message length would exceed 160 characters, the serial number of the data logger will be displayed instead of the description.
- *measured values of single quantities* – the channel number or channel description (if it is set) is displayed, the measured value and the quantity unit follow. If the measured value exceeds any alarm limit, the symbol „!“ will be displayed in front of the value.

The response message example:

Logger Store_13: Temp: 24.7C Hum: 45.5%RH DP: !12.1C

If it is not possible to take information about the measured values, i.e. the data logger is switched off or a communication error between the modem and the data logger has occurred, the modem will send back a SMS message with a proper error description.

The command	
values	The command for reading of the current values.
An example of the response message	
Logger Store_13: Temp: 24.7C Hum: 45.5%RH DP: !12.1C	The current values from the data logger.
The logger is switched off	A query can't be processed, because the data logger is switched off.
An error occurred during communication with the logger	A query can't be processed, because a communication error between the modem and the data logger has occurred.

5.1.2. The query about the current values and their alarm limits

To take the current measured values from the connected data logger and their alarm limits, send the SMS message **values!** to the modem. The content of the response message is the same with a query **values**. In addition, this response message includes their alarm limits in this case.

The response message example:

Logger Store_13: Temp: 24.7C 19.0..26.0 Hum: 45.5%RH 0.0..50.0 DP: !12.1C 0.0..10.0

The command	
values!	The command for reading of the current values and their alarm limits.
An example of the response message	
Example 1: #12345678: #1: 24.7C 19.0..26.0 #2: 45.5%RH 0.0..50.0 #6: !12.1C 0.0..10.0 Example 2: Logger Store_13: Temp: 24.7C 19.0..26.0 Hum: 45.5%RH 0.0..50.0 DP: !12.1C 0.0..10.0	The current values and their alarm limits from the data logger.
The logger is switched off	A query can't be processed, because the data logger is switched off.
An error occurred during communication with the logger	A query can't be processed, because a communication error between the modem and the data logger has occurred.

5.1.3. The query about the modem firmware version

To take the modem firmware version, send the SMS message **firmware** to the modem.

The command	
Firmware	The command for reading of the modem firmware version.
An example of the response message	
Datalogger Communicator v. 1.1.0	The modem firmware version.

5.1.4. The query about the current modem state information

To take the current modem state information, send the SMS message **gsmstatus** to the modem. The modem will send back a SMS message with followed information:

The command	
gsmstatus	The command for reading of the current modem state information.
An example of the response message	
Uptime: 0d 0hr 26min;M2MTalk online: yes;Operator: "T-Mobile CZ","T-Mobile CZ";RSSI: 66dbm;Signal: 99;Registered on network: yes;Roaming: no	Elapsed time from the modem's switching on.
	The current M2MTalk server login status.
	The name of GSM operator.
	The signal strength [dBm].
	The signal quality.
	The SIM card registration on the cellular network (GSM).
	The SIM card registration on the foreign network (it says if the roaming is active).

5.2. The statement SMS messages

Using these messages, you can control and set up the modem remotely.

5.2.1. Login on the M2MTalk server

If you intend to use remote communication with the modem or data logger via GPRS (for example to set up this device remotely), the modem always must be logged on the M2MTalk server before starting the communication. The modem can be set up to login on the server automatically after its switching on, but it isn't a standard factory setting.

To login the modem on the M2MTalk server, you can send a SMS message **login** to the modem phone number. The modem will send back an acknowledge SMS message.

The command	
login	The command for login on the M2MTalk server.
The response message	
The demand for login on the server was accepted	Information about acceptance of demand for login on the M2MTalk server.
This module is already logged on the server	The message - the modem was already logged on the M2MTalk server.

5.2.2. Logout from the M2MTalk server

Since the modem is logged on, a limited data transferring also proceeds in case the remote communication with the device isn't in progress (due to keeping the connection). Transferred data is charged as per your GPRS tariff by the mobile operator. If you intend to use remote communication via GPRS no longer, you can logout the modem from the M2MTalk server to reduce transferred data.

The command	
<code>logout</code>	The command for logout from the M2MTalk server.
The response message	
<code>The demand for logout on the server was accepted</code>	Information about acceptance of demand for logout from the M2MTalk server.
<code>This module is not logged on the server</code>	The message - the modem wasn't logged on the M2MTalk server.

5.2.3. Restart of the modem

This command is intended for the remote restart of the modem, for example in the event of the problem with GPRS connection. The complete restart of the modem takes about 2 minutes.

The command	
<code>restart</code>	The command for restart of the modem.
The response message	
<code>The demand for application restart was accepted</code>	Information about acceptance of demand for restart of the modem.

5.2.4. Information about the GPRS connection settings

If the SMS message `gprs` without any parameters is sent, the modem will send back the SMS message with information about the current GPRS connection settings.

The command	
<code>gprs</code>	The command for reading of information about the GPRS connection settings.
An example of the response message	
<code>APN='internet' User='' Password='' DNS=''</code>	Information about the GPRS connection settings.

5.2.5. Setting of the GPRS connection

The first word of the message must always be **gprs**. After this keyword, parameter values for an actual setting follows in specific order:

gprs [apn] [user] [password] [dns]

If the trailing parameter values are not entered, they will be deleted. Don't enter the square brackets in the SMS message. Individual items of the message must be separated by spaces. The meaning of the parameters is following:

- **apn** the access point name
- **user** the user name for login
- **password** the password for login
- **dns** the DNS server name or IP address

If any of the parameters **user**, **password** or **dns** are not entered „from the back“, they will be always deleted.

If the modem accepts the command, the SMS message will be sent back. And if the modem was logged on the M2MTalk server, the modem will be restarted automatically.

An example of the command with parameters	
<code>gprs internet</code>	Setting of the parameter apn to the value internet . The values of the parameters user , password and dns will be deleted.
The response message	
<code>GPRS parameters were set and stored</code>	All parameters were set and stored correctly.
<code>An error occurred while setting GPRS parameters</code>	An error occurred during setting the parameters. Their saving didn't succeed.

If all values to store are the same as the original already stored values, executing the command will have no effect. In this case, the modem will only send back the same information as in the case of *Information about the GPRS connection settings*. So if only the information is sent back though the user entered the setting command, it means all parameters are already set as required (it wasn't needed to change them).

5.2.6. Information about the M2MTalk server connection settings

If the SMS message **m2mtalk** without any parameters is sent, the modem will send back the SMS message with information about the M2MTalk server connection settings.

The command	
<code>m2mtalk</code>	The command for reading of information about the M2MTalk server connection settings.
An example of the response message	
<code>Enabled='yes' Autologin='yes' Address='1234' User='usr' Password='psw' Server='example.com' Port='9999'</code>	Information about the M2MTalk server connection settings.

5.2.7. Setting of the M2MTalk server connection

The first word of the message must always be **m2mtalk**. After this keyword, parameter values for an actual setting follows in specific order:

m2mtalk [*enabled*] [*autologin*] [*address*] [*user*] [*password*] [*server*] [*port*]

If the trailing parameter values are not entered, they will be unchanged. Don't enter the square brackets in the SMS message. Individual items of the message must be separated by spaces. The parameters are optional „from the back“. If any parameter isn't entered, it will not be changed. The meaning of the parameters is following:

- **enabled** enable the communication via M2MTalk server (**yes/no**)
- **autologin** automatic login on the server after switching on the modem (**yes/no**)
- **address** the modem address (a number value)
- **user** the user name for login (a text)
- **password** the password for login (a text)
- **server** the M2MTalk server name or IP address (a text)
- **port** the port number (a number value)

If the modem accepts the command, the SMS message will be sent back. And if the modem was logged on the M2MTalk server, the modem will be restarted automatically.

An example of the command with parameters	
<code>m2mtalk yes no 2006 2006 mypsw</code>	The communication via M2MTalk server will be enabled, automatic login after switching on will be deactivated, address will be 2006, user name will be 2006 and the password will be mypsw. The M2MTalk server name or IP address and the port number stay unchanged.
The response message	
<code>M2MTalk server parameters were set and stored</code>	All parameters were set and stored correctly.
<code>An error occurred while setting M2MTalk server parameters</code>	An error occurred during setting the parameters. Their saving didn't succeed.

If all values to store are the same as the original already stored values, executing the command will have no effect. In this case, the modem will only send back the same information as in the case of *Information about the M2MTalk server connection settings*. So if only the information is sent back though the user entered the setting command, it means all parameters are already set as required (it wasn't needed to change them).

5.2.8. Information about permitting of the alarm SMS messages

If the SMS message **alarms** without any parameters is sent, the modem will send back the SMS message with information whether sending of the alarm SMS messages is enabled or not.

The command	
alarms	The command for reading of information about permitting of the alarm SMS messages.
The possible response messages	
Sending of warning messages is switched on	Sending of the alarm SMS messages is enabled.
Sending of warning messages is switched off	Sending of the alarm SMS messages is disabled.

5.2.9. Setting of permitting of the alarm SMS messages

The syntax of this command is either **alarms on** or **alarms off**. In the first case, sending of the alarm SMS messages will be enabled. Alarm states will be checked periodically. If any alarm occurs, the alarm SMS message will be sent to the predefined phone numbers. In the second case, sending of the alarm SMS messages will be disabled.

The command	
alarms on	Sending of the alarm SMS messages will be enabled.
An example of the response message	
Sending of warning messages was switched on from number +420123456789	Sending of the alarm SMS messages was enabled from the phone number +420123456789.
An error occurred while switching sending of warning messages on	The error occurred, saving of the parameter didn't succeed.

The command	
alarms off	Sending of the alarm SMS messages will be disabled.
An example of the response message	
Sending of warning messages was switched off from number +420123456789	Sending of the alarm SMS messages was disabled from the phone number +420123456789.
An error occurred while switching sending of warning messages off	The error occurred, saving of the parameter didn't succeed.



Attention! If this setting is performed successfully, the response message will be sent not only to sender's phone number, but also to all phone numbers for the warning SMS messages recipients!

If the value to store is the same as the original already stored value, executing the command will have no effect. In this case, the modem will only send back the same information as in the case of *Information about permitting of the alarm SMS messages*. So if only the information is sent back though the user entered the setting command, it means the parameter is already set as required (it wasn't needed to change it).

5.3. The alarm SMS messages

These messages are being sent to the predefined phone numbers independently of the user (see the chapter *Settings of the communication with the modem and the modem parameters* on page 24). The information about exceeding of alarm limits and about correct operation of the data logger can be periodically taken from the data logger by the modem. Concretely, following data logger states are monitored:

- the measured value exceeds the alarm limit (the alarm is active)
- communication error
- the data logger state (switched on / off)
- the data logger real time clock error
- the data logger memory is 90% full
- the data logger memory is full
- the expected data logger battery life expired
- the data logger battery voltage is too low

If GPRS connection isn't activated, you will have to set up the alarm SMS messages parameters by using the setting cable. Following parameters must be set with the program for data loggers:

- data logger reading interval
- sending / no sending of the warning SMS messages
- phone numbers for the warning SMS messages recipients

5.3.1. The measured value exceeds the alarm limit

Exceeding of the alarm limit is evaluated by the data logger. To work it correctly, following parameters must be set for the data logger:

- the data logger must be switched on
- the alarm limits must be set with desired means for all monitored quantities
- the alarm evaluating must be enabled for all monitored quantities

The incoming SMS message begins with the user's description of the data logger. If the description isn't set for the data logger, the serial number of the data logger will be displayed. If the total message length would exceed 160 characters, the serial number of the data logger will be displayed instead of the description. The symbol „!“ is displayed in front of the value which exceeds any alarm limit.

The incoming alarm SMS message	
Example 1: #12345678: #1: 24.7C 19.0..26.0 #2: 45.5%RH 0.0..50.0 #6: !12.1C 0.0..10.0 Example 2: Logger Store_13: T: 24.7C 19.0..26.0 RH: 45.5%RH 0.0..50.0 DP: !12.1C 0.0..10.0	The current values and their alarm limits from the data logger.

5.3.2. The data logger states

Communication error

The incoming alarm SMS message	
An error occurred during communication with the logger	An error occurred while communication between the modem and the data logger.

The data logger state (switched on / off)

The incoming alarm SMS message	
The logger is switched off	The data logger is switched off.

The incoming alarm SMS message	
The logger is switched on	The data logger is switched on.

The data logger real time clock error

The incoming alarm SMS message	
The logger real time clock error	The data logger real time clock isn't adjusted correctly.

The data logger memory is 90% full

The incoming alarm SMS message	
The logger memory is 90% full	The data logger memory is 90% full.

The data logger memory is full

The incoming alarm SMS message	
The logger memory is full	The data logger memory is full.

The expected data logger battery life expired

The incoming alarm SMS message	
The end of the expected logger battery life	The expected data logger battery life expired.

The data logger battery voltage is too low

The incoming alarm SMS message	
The logger power supply is low	The data logger battery voltage is too low.

6. Settings of the program for data loggers to use it with the modem

Attention! If GPRS connection isn't available, you will have to use the setting cable. Move ahead the chapter *Setting of the modem using the setting cable* on page 30.

All following parameter settings are mentioned for an information only, the correct values must be entered everywhere!

6.1. Settings of the communication with the modem and the modem parameters

Run the program for data loggers. Select the item *File / Options* in the main menu. In the window *Options*, select the item *M2M connection* on the left bar first. A following window will be displayed.

The screenshot shows a Windows-style dialog box titled "Options". On the left is a tree view with the following items: "Data storing", "Communication", "Data presentation", "M2M connection" (highlighted in blue), and "Autodownload". The main content area is titled "M2M connection (PC to M2M server)". Underneath, there is a section labeled "Connection parameters" containing four input fields: "Server" (text box with "talk.server.m2msensor.com"), "Port" (spin box with "9999"), "PC's M2M address" (spin box with "2002"), and "M2M login password" (password box with "*****"). Below these fields is a "Connection test" button. At the bottom of the dialog are three buttons: "Apply" (with a refresh icon), "OK" (with a checkmark icon), and "Close" (with a window icon).

The items *Server* and *Port* are already pre-filled, don't change it gratuitously! Fill the items *PC's M2M address* a *M2M login password* with data listed in the card which was delivered with the modem. Confirm these settings with pressing *Apply* button.

Further, in the window *Options*, select the item *Communication* on the left bar. A following window will be displayed.

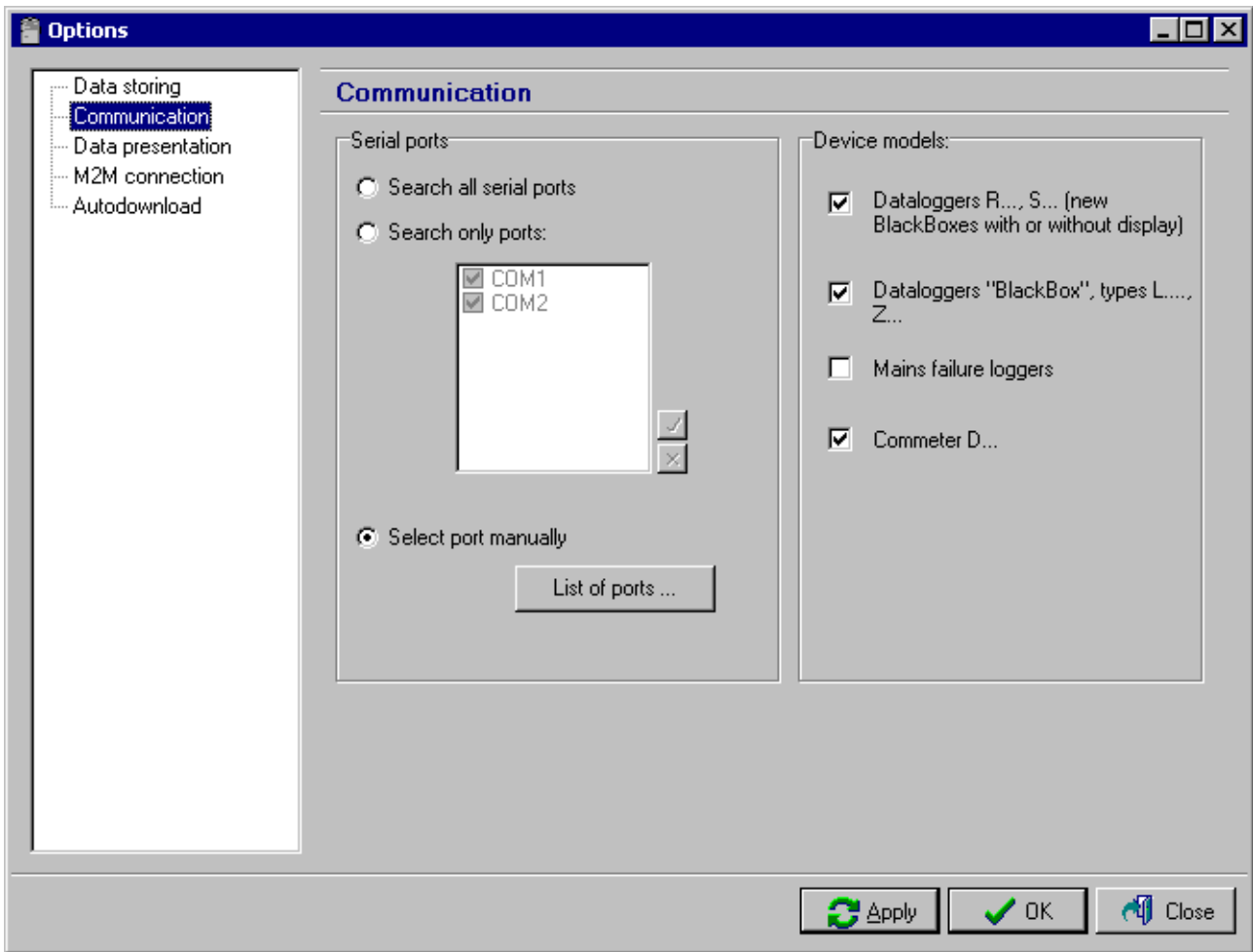

Select the item *Select port manually* and press the button *List of ports....* The window *List of communication ports* will be displayed.

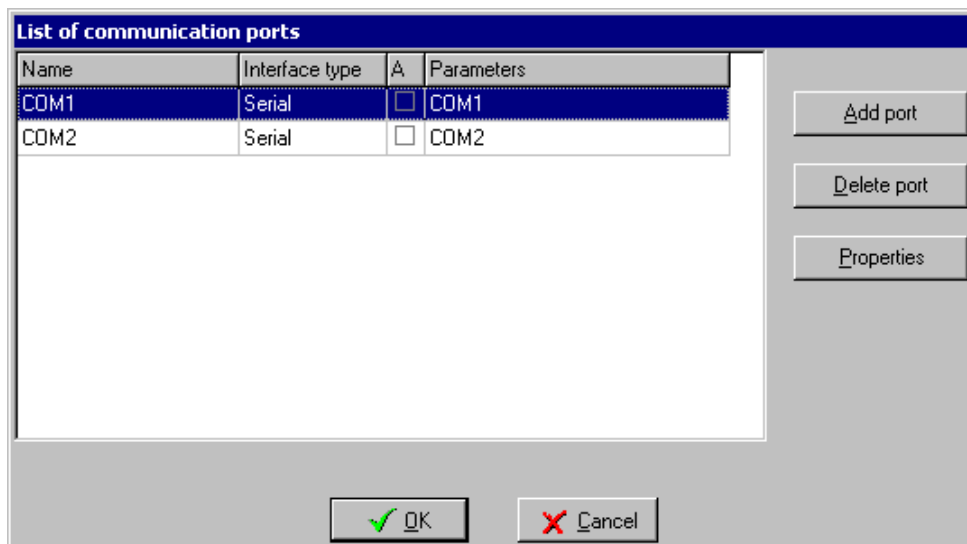

In this window, press the button *Add port*. The window *Add communication port* will be displayed.



Select the item *GPRS (M2M modem)* here and then press the button *Next >*.

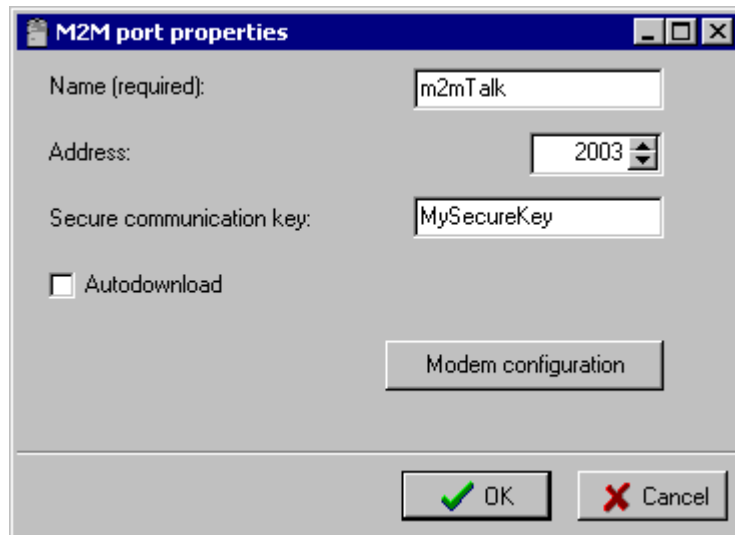

The window *M2M port properties* will be displayed. Set the connection parameters for the modem here. The item *Name* is intended for user's description of connection, choose your own name. Fill the item *Address* with data listed in the card which was delivered with the modem. If you want to prevent unauthorized access to your modem (data logger), you will have to fill the item *Secure communication key* with your entered password. Remember this password well, it will have to be entered during setting of the modem later!

Continue with pressing *Modem configuration* button. Communication with the modem begins. If all previous settings are correct, a following window will be displayed. If not, please check the settings described in the chapter *Settings of the communication with the modem and the modem parameters* on page 24.

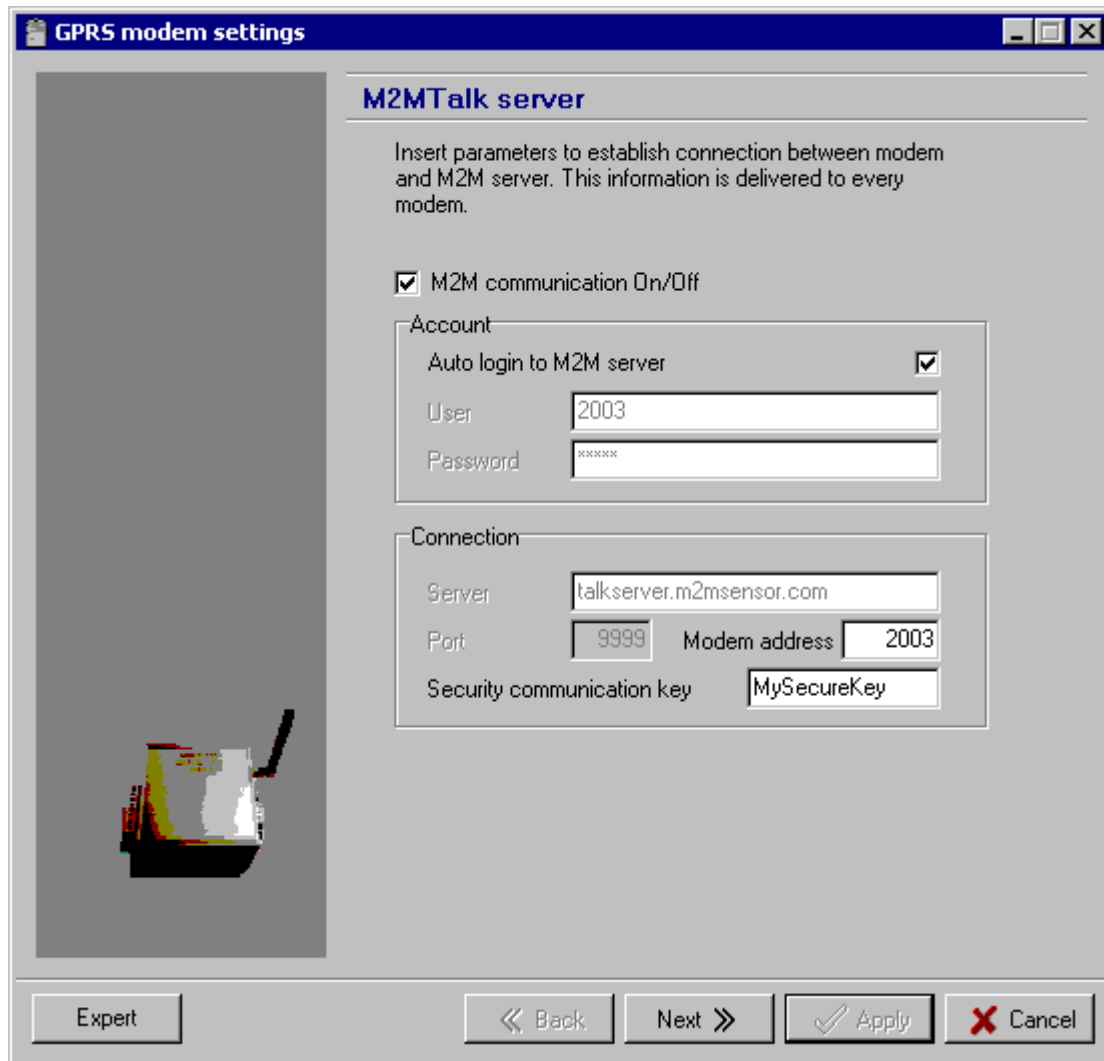

In this window, enter *Security communication key* according to setting in the window *M2M port properties* on page 26. If you require the modem's login on the server automatically after its switching on (so that GPRS communication can be available), you will have to tick off the field *Auto login to M2M server*. Don't change other parameters in this window gratuitously, it can cause problem with communication!

After pressing *Next >>* button, the window for settings of phone numbers restriction for communication via SMS messages will be displayed.

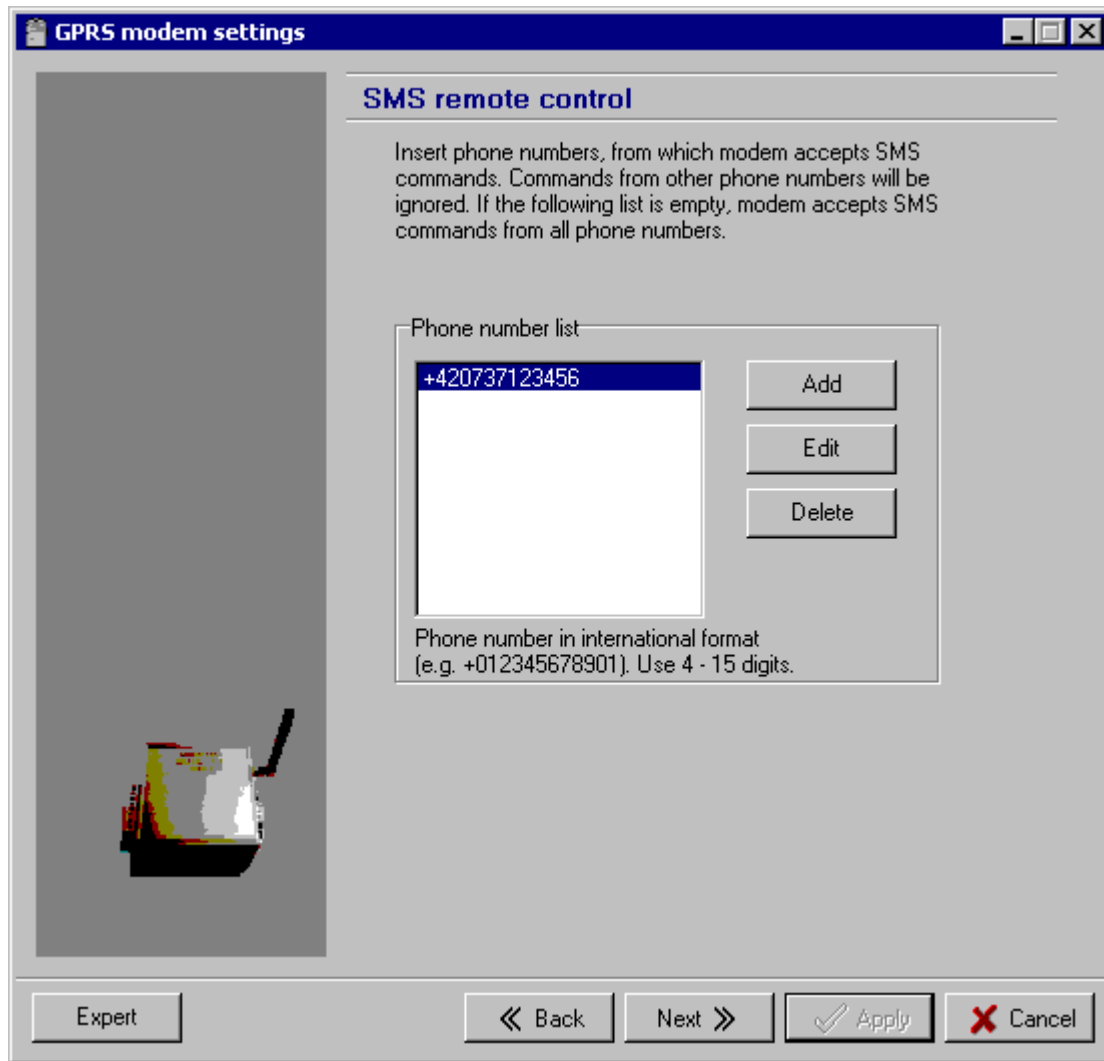

Communication via SMS messages can be restricted to selected phone numbers only. If no phone numbers are in the list, the modem will process the incoming SMS messages from all phone numbers. If you add some phone numbers to this list, the modem will process the incoming SMS messages only from these selected phone numbers.

After pressing *Add* button, enter the phone numbers from which you want to send SMS command messages to the modem. All phone numbers must have the international format (for example +420123456789).

After pressing *Next >>* button, the window for settings of the alarm SMS messages parameters will be displayed.

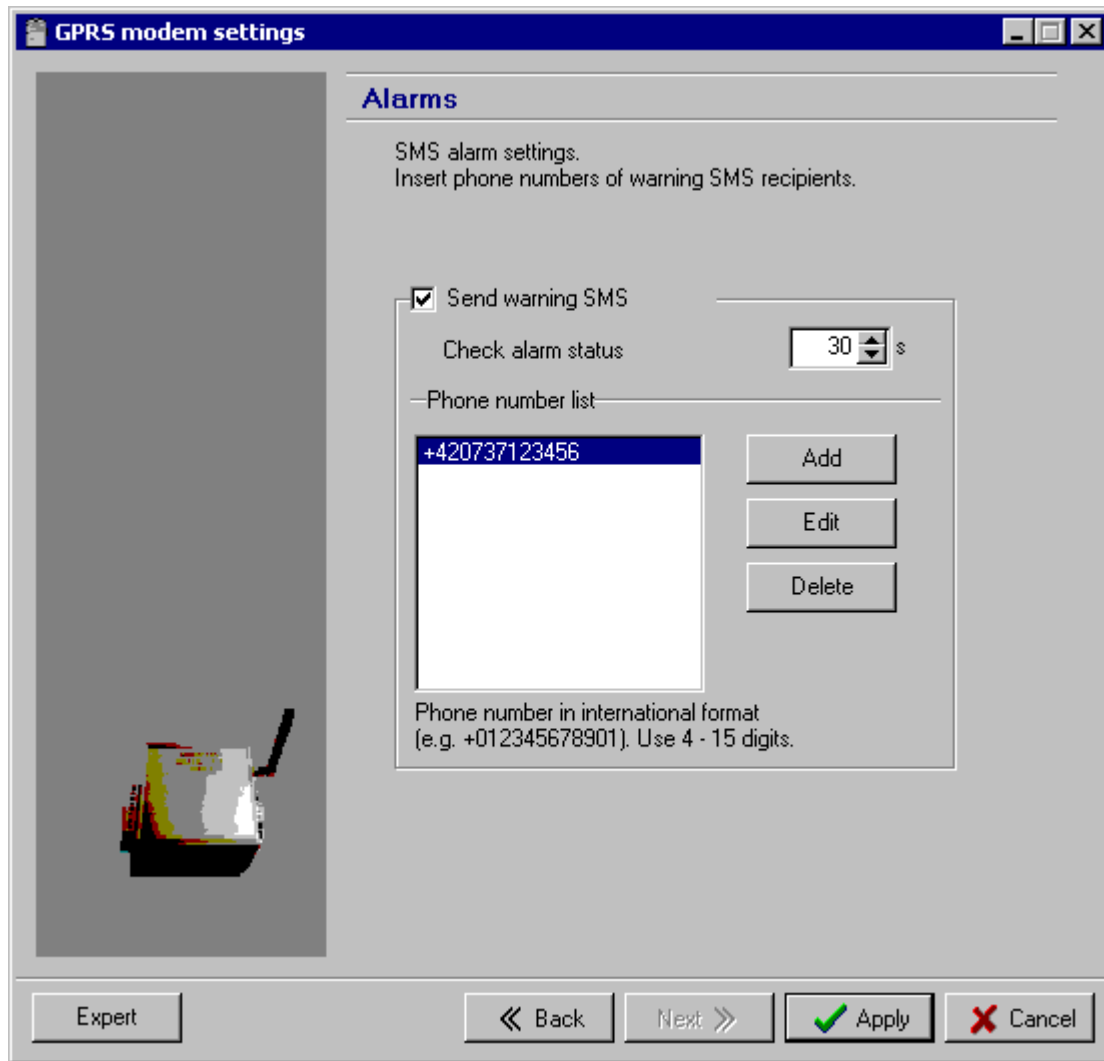

The information about exceeding of alarm limits and about correct operation of the data logger can be periodically taken (according to the item *Check alarm status*) from the data logger by the modem. These information are processed and then the modem sends alarm SMS messages to a customer according to these analyses. If you require sending of the warning SMS messages by the modem, you will have to tick off the field *Send warning SMS* and enter the phone numbers for the warning SMS messages recipients.

After pressing *Apply* button, all settings are stored into the modem and then the modem will be restarted. Confirm all opened windows with pressing *OK* button.

6.2. Setting of the data logger parameters

If you require sending of the warning SMS messages by the modem (for example in the case of exceeding of the alarm limits), you will have to set these data logger parameters at least:

- the data logger must be switched on
- the alarm limits must be set with desired means for all monitored quantities
- the alarm evaluating must be enabled for all monitored quantities

If you use GPRS connection for communication with the data logger, you will be allowed to set up the data logger remotely by using the program for data loggers. For the remote connection you must select the item *Select port manually* in the window *File / Options / Communication* and confirm it with pressing *OK* button. Then select the item *Configuration / Device setting* in the main menu. Choose the correct communication port name from the displayed list.

If you don't use GPRS connection for communication with the data logger, you will be allowed to set up the data logger locally via the proper communication adapter (COM adapter, USB adapter). Use the program for data loggers to set up data logger.

6.3. Setting of the modem using the setting cable

If GPRS connection isn't available, you will have to use the setting cable for setting up the modem with no limitations. In this case, the program for data loggers must be run with the parameter */service*. The available way how to achieve it: click on the button *Start*, select the item *Run...*, then select the item *Browse...*, find the program *LOGGER.EXE* in your drive (if the destination of this program wasn't changed during installation, it will be placed in the directory *C:\Program Files\CometLoggers\Logger\Logger.exe*), select it by using the mouse and click on the button *Open*. In the displayed field *Open*, write the char space followed by parameter */service* at the end of displayed path (past the quotation mark). Then click on the button *OK*. After program start, the submenu *Service* should appear in the main menu. Select the item *M2M modem* in the submenu *Service*. Choose the correct COM port number and confirm it with pressing *OK* button. Now you can set up all modem parameters with no limitations.

7. Technical specification

7.1. Technical parameters

Communication with the device:	RS232 (connector Canon 9) for the COM adapter
Frequency band:	850/900/1800/1900 MHz
Output power:	Class 4 (+33dBm ±2dB) for EGSM850 Class 4 (+33dBm ±2dB) for EGSM900 Class 1 (+30dBm ±2dB) for GSM1800 Class 1 (+30dBm ±2dB) for GSM1900
SIM card type:	1,8V or 3V
GPRS class:	multislot class 12
Antenna:	50 ohm, SMA connector
Supply terminal block:	removable, WAGO 734, max. size of conductors 1.5 mm ²
IP code:	IP30
Operating conditions:	The power supply: external 9-32V DC, peak input up to 10W The operating temperature range: from -30°C to +65°C External characteristics determination by EN33-2000-3: Environment standard as per NM with these corrections: AE1, AN1, AR1, BE1 Operating position: arbitrary Device mounting (optional equipment): self-adhesive Dual Lock, wall holder, DIN rail holder
Storage conditions:	temperature from -40°C to +85°C
Dimensions:	105 x 71 x 24mm (without antenna and holders)
Weight:	cca 180g (without antenna and holders)
Box material:	anodized aluminum

7.2. The modem interface

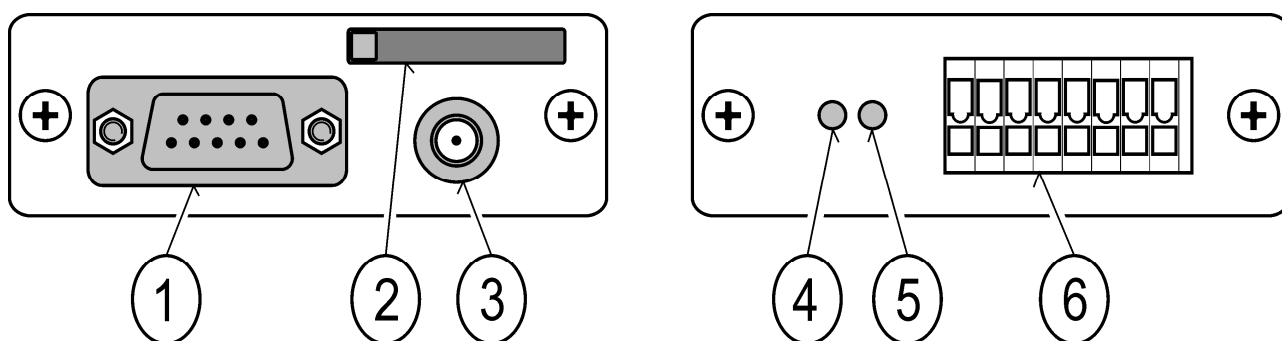

1 = RS232 connector, 9 pin, male
2 = SIM card holder and connector
3 = antenna connector, SMA, female

4 = yellow indicator LED
5 = green indicator LED
6 = supply terminal block, WAGO

7.3. A directory information about dimensions with the GSM antenna MP009/1

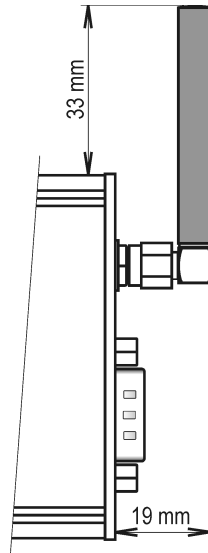

7.4. Dimensional drawing for a wall mounting of the modem with MP036

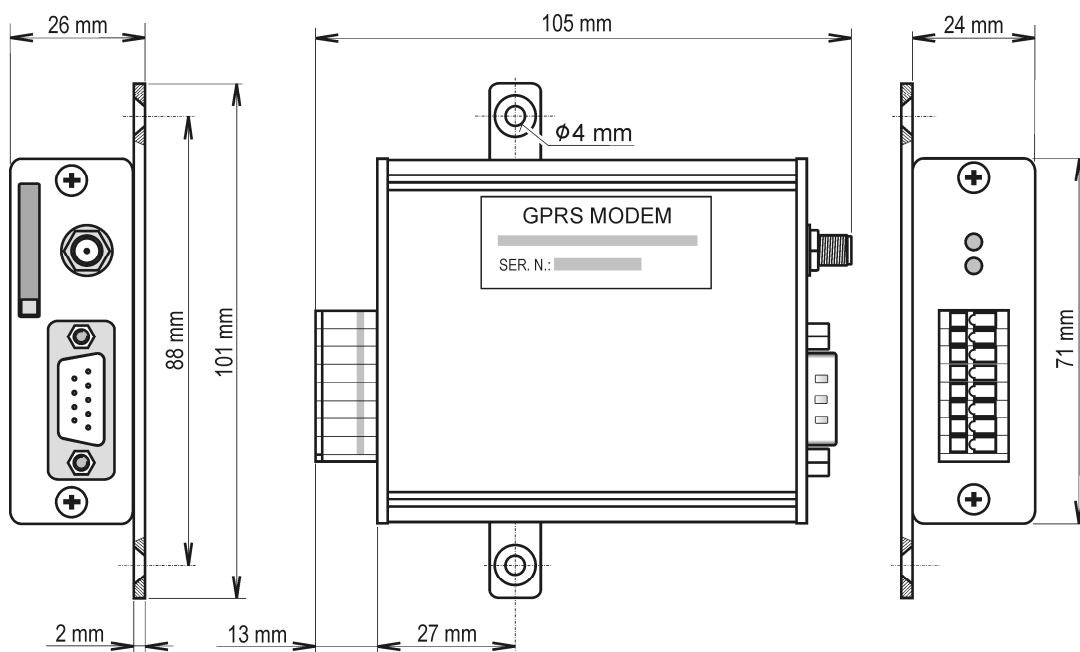

7.5. Dimensional drawing for a DIN rail mounting of the modem with MP037

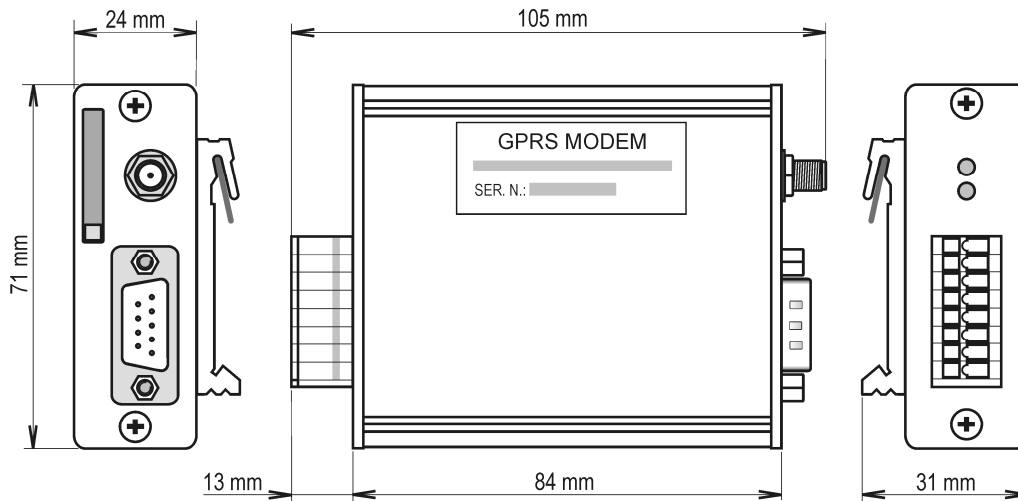

7.6. Description of the indicator LEDs

The green indicator LED	The reason
does not light	the modem isn't connected to a power supply
lights	the modem power supply is on, this is a correct operation
switches off for a short time (every cca 30s)	a checking signal, this is a correct operation
blinks	the modem is restarting (restart takes about 1 minute)

The yellow indicator LED	The reason
does not light	a GSM part is switched off
blinks one time for a short time every cca 3s	the modem is successfully connected via the cellular network (GSM), i.e. the modem replies for the SMS messages, GPRS isn't connected
blinks two times for a short time every cca 3s	GPRS connection is active, i.e. it is possible to communicate with the data logger remotely, the modem replies for the SMS messages
blinks regularly	<ul style="list-style-type: none"> - the SIM card is not inserted - a PIN code isn't deactivated on the SIM card - the GSM antenna isn't mounted - searching for the network is in progress - login to the network is in progress

7.7. The list of the supported data logger types

Firmware version	The supported data logger types
1.0.0	R0110, R0111, R0121, R0122, R0141, R0841, R3120, R3631, R3541, R6011, R6021, R5011, R5021, R3121, R0110E
1.0.1	S0110, S0111, S0121, S0122, S0141, S0841, S3120, S3631, S3541, S6011, S6011, S6021, S6021, S5011, S5011, S5021, S5021, S3121, S7021, S0541, S0442, S3532, S7841, S0842, S0110E, S0110F, S0111F

8. Technical support

Technical support is provided by a distributor of this device. The contact is presented in the included warranty certificate. In case of need, you can also make use of a discussion forum on <http://www.forum.cometsystem.cz/>.

A short description of the discussion forum is on <http://www.cometsystem.cz/forum.htm>.

9. Liquidation

The device must be liquidated ecologically after its disconnecting!