

TEMPERATURE AND HUMIDITY TRANSMITTERS with 0-10V output

temperature * relative humidity * dew point temperature * absolute humidity * specific humidity * mixing ratio * specific enthalpy



Transmitter TO213



Transmitter TO210



Transmitter TO211, TO211P



Transmitter TO213D - duct mount

Programmable temperature and humidity transmitters are equipped with temperature and relative humidity sensors. Measured values are also converted to other humidity interpretation - dew point temperature, absolute humidity, specific humidity, mixing ratio or specific enthalpy. Degrees Celsius and Fahrenheit are user selectable. Transmitters are available in wall-mount, duct-mount and bar types. Also types with T+RH probe on a cable are available. Transmitter contains a control circuitry in a durable plastic case with connection terminals and sensors in a stainless steel mesh filter. Humidity transmitters are also available with two 0-10V outputs. Configuration of outputs and output range are user adjustable. Large dual line LCD for simultaneous display of T+RH, or other humidity interpretation is an advantage. Display is possible to switch off. Computerized design ensures temperature compensation of the humidity sensor and fail indication. State-of-the-art capacitive polymer sensor ensures excellent calibration long term stability, inertia against water and condensation. Transmitters are designed for use in non-aggressive environment.

TECHNICAL PARAMETERS

Relative humidity operating range:	0 to 100%
Accuracy of relative humidity output:	±2.5% relative humidity from 5 to 95% at 23 °C
Accuracy of temperature output:	±0.4 °C from -30 to +100 °C, ±0.4% from reading over +100 °C
Accuracy of temperature output of T4111:	±0.15 °C + 0.1% from adjusted output span (without temperat. probe)
Accuracy and range of dew point temperature output:	±1.5 °C at ambient temperature < 25 °C and RH>30%, range -60 to +80 °C
Accuracy and range of absolute humidity output:	±3g/m ³ at ambient temperature T < 40 °C, range 0 to 400 g/m ³
Accuracy and range of specific humidity output:	±2g/kg at ambient temperature T < 35 °C, range 0 to 550 g/kg
Accuracy and range of mixing ratio output:	±2g/kg at ambient temperature T < 35 °C, range 0 to 995 g/kg
Accuracy and range of specific enthalpy output:	± 3kJ/kg at ambient temperature T < 25 °C, range: 0 to 995 kJ/kg
Temperature operating range of the case:	-30 to +80 °C
Temperature operating range of the LCD display:	readable to +70 °C, recommended to switch off LCD over +70 °C
Range of temperature compensation of RH sensor:	-30 to +125 °C
Voltage outputs:	0-10V, dual-output models have common ground, galvanically unisolated
Configuration of outputs and output range:	user adjustable from the PC
Filtering ability of sensor cover:	0.025mm
Power:	15-30Vdc, maximum consumption 20mA
Dimensions of the case with electronics (W x H x D):	89 x 73 x 39.5 mm
Protection of the case with electronics:	IP65 electronics, IP40 sensors

TEMPERATURE AND HUMIDITY TRANSMITTERS with 0-10V output

TRANSMITTERS ARE AVAILABLE IN THE FOLLOWING MODELS:

MODEL	MEASUR. VALUE	MAXIMUM RANGE OF TEMPERATURE MEASUREMENT	STEM LENGTH	OUTPUT 1 ²⁾	OUTPUT 2 ²⁾	NOTE
TO210	RH+T	-30 to +80 °C	75mm	0-100%RH ²⁾	-30 to +80 °C ²⁾	outdoor and indoor use
TO213	RH+T	-30 to +125 °C ¹⁾	150mm	0-100%RH ²⁾	-30 to +125 °C ²⁾	duct mount
TO211	RH+T	-30 to +105 °C ¹⁾ probe including cable	probe cable 1,2,4m	0-100%RH ²⁾	-30 to +105 °C ²⁾	T+RH probe with 1m cable. Diameter 18mm, length 90mm. Cable lengths 2m or 4m available.
TO211P	RH+T up to 25bars	-30 to +105 °C ¹⁾ probe including cable	probe cable 1,2,4m	0-100%RH ²⁾	-30 to +105 °C ²⁾	Compressed air up to 25bars. T+RH metal probe with 1m cable. Cable lengths 2m or 4m available. Diameter 18mm, length 110mm, thread G1/2. See optional accessory.

1) Maximum temperature only at the measuring end with sensors. Maximum temperature +105 °C for TO211 with cable probe is allowed also for the cable. Relative humidity at temperature over +85 °C is limited in accordance with the graph. Near plastic case with electronics maximum temperature is +80 °C.

2) Any measured value - temperature, relative humidity, dew point temperature, absolute humidity, specific humidity, mixing ratio or specific enthalpy can be assigned to each output of dual output transmitters. Also identical value can be assigned to both outputs. Outputs are adjusted to maximum range from the manufacturer. Output range is user adjustable from the PC by means of the optional cable SPO03 - see photo. Free configuration program for transmitter adjustment is ready to download anytime from www.cometsystem.cz.

If different adjustment of outputs and output ranges are required, please specify required output values (RH, T, Tdp, ...) and required ranges.

Ordering example: Transmitter TO210, output 1: RH 10 to 90%, output 2: temperature 0 to 35 °C

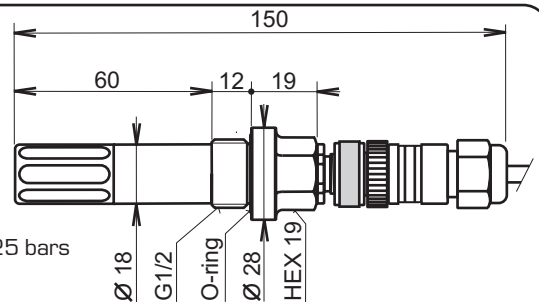

TO211P transmitter T+RH, dewpoint metal probe for compressed air up to 25 bars

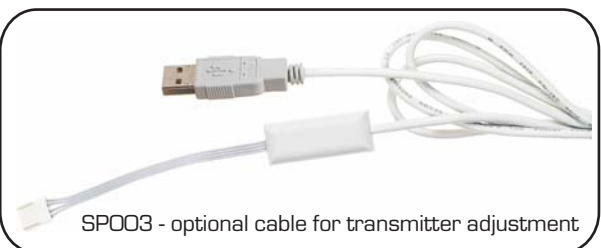
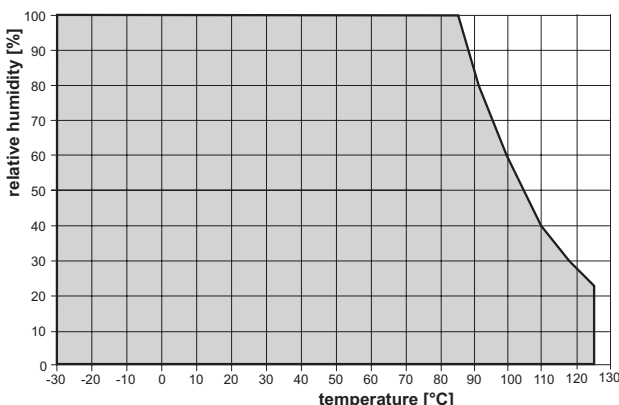

SPO03 - optional cable for transmitter adjustment

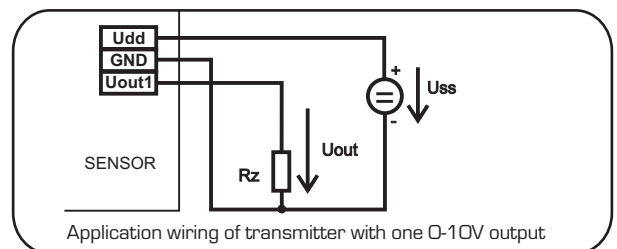

Application wiring of transmitter with one 0-10V output

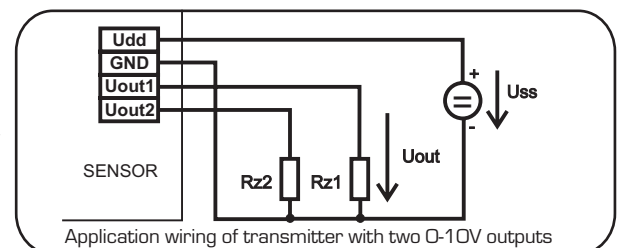

Application wiring of transmitter with two 0-10V outputs

Included accessory:

Traceable calibration certificate from the manufacturer, instruction manual. Calibration certificate with declared metrological traceability of etalons is based on requirements of EN ISO/IEC 17025 standard.

Free program TSensor for configuring of the transmitter is ready to be downloaded from www.cometsystem.cz.

Other optional accessory: see further

Pxxxx Txxxx